

EUROCAP – for non-armoured round cables

Technical specifications



Suitable for the following cable types



Non-armoured cable

Cable with insulated conductors, with no layer of mechanical (metallic) protection.



Certifications

EN 62444

UL certificate: E172126

CSA certificate: 701907

Continuous operating temperature

-40 °C to +100 °C

Colour

Grey RAL 7035 or Black RAL 9005

Material

Polyamide 6/6 – UL 94 V0 – halogen free

ISO (metric) threadforms

ISO-NF EN 60423 and EN 62444

Pg electrical threadforms

UTE C 68-311 – DIN 40430

Perfectly adapted to industrial environments

Supplied with neoprene gasket

- Maximum temperature: +150 °C
- IP68: 5 bars without sealing washer provided that the bearing area is satisfactory except for Pg36/42/48 and ISO40/50/63 in accordance with NF EN 60529

Dimensions

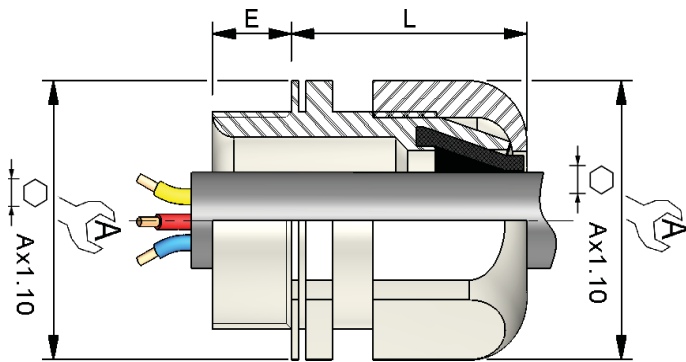

* For 'across corners' dimensions, multiply 'across flats' dimensions by 1.1

Our range of versatile plastic industrial cable glands EUROCAP allows the connection of non-armoured cables. It is provided with ISO or Pg threads.

The neoprene sealing ring achieves both an IP68 tightness on the outer sheath of the cable as well as a perfect tensile strength.

The cable gland, manufactured from polyamide 6.6, complies with the requirements of the UL94 V0 classification.

With an operating temperature range of -40°C to +100°C, the EUROCAP range fully meets harsh industrial environments constraints.

Ordering codes

Thread Size (ISO)	Cable Diameter Min - Max				Order Unit	Cable Gland		Sealing Gasket	Catalog Number	
		A	L	E		Grey	Black		Grey	Black
M12	3.0 - 6.5	15	21	8	20	CAP401270	CAP401260	CAP221249	CAP261273	CAP261203
M16	4.0 - 8.0	19	25	8	20	CAP401670	CAP401660	CAP221649	CAP261673	CAP261603
M20	6.0 - 12.0	24	33	9	20	CAP402070	CAP402060	CAP222049	CAP262073	CAP262003
M25	12.0 - 18.0	33	36	11	20	CAP402570	CAP402560	CAP222549	CAP262573	CAP262503
M32	17.0 - 25.0	42	40	11	10	CAP403270	CAP403260	CAP223249	CAP263273	CAP263203
M40	20.0 - 32.0	53	36	11	1	CAP404070	CAP404060	CAP224049	CAP264073	CAP264003
M50	26.0 - 38.0	60	36	11	1	CAP405070	CAP405060	CAP225049	CAP265073	CAP265003
M63	30.0 - 44.0	68	36	11	1	CAP406370	CAP406360	CAP226349	CAP266373	CAP266303

Thread Size (Pg)	Cable Diameter Min - Max				Order Unit	Cable Gland		Sealing Gasket	Catalog Number	
		A	L	E		Grey	Black		Grey	Black
Pg7	3.5 - 6.5	15	21	8	20	CAP410770	CAP410760	CAP240749	CAP260770	CAP260760
Pg9	4.0 - 8.0	19	25	8	20	CAP410970	CAP410960	CAP240949	CAP260970	CAP260960
Pg11	5.0 - 10.0	22	29	8	20	CAP411170	CAP411160	CAP241149	CAP261170	CAP261160
Pg13	6.0 - 12.0	24	33	9	20	CAP411370	CAP411360	CAP241349	CAP261370	CAP261360
Pg16	9.0 - 14.0	27	34	10	20	CAP411670	CAP411660	CAP241649	CAP261670	CAP261660
Pg21	12.0 - 18.0	33	36	11	20	CAP412170	CAP412160	CAP242149	CAP262170	CAP262160
Pg29	17.0 - 25.0	42	40	11	10	CAP412970	CAP412960	CAP242949	CAP262970	CAP262960
Pg36	20.0 - 32.0	53	51	13	10	CAP413670	CAP413660	CAP243649	CAP263670	CAP263660
Pg42	26.0 - 38.0	60	50	13	1	CAP414270	CAP414260	CAP244249	CAP264270	CAP264260
Pg48 DIN	30.0 - 44.0	65	53	14	1	CAP414870	CAP414860	CAP244849	CAP264878	CAP264879